

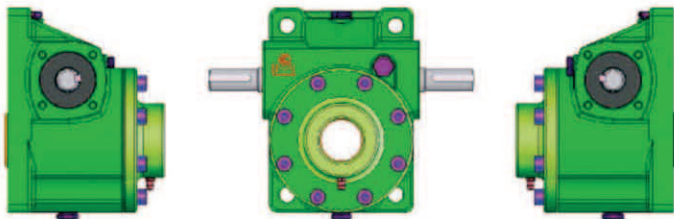

SCREW JACK REDUCER SERIES

■ VARIETY OF INPUT TRANSMISSION

Double Input Shaft (VJ Standard Type)



Rotation Direction & Movement

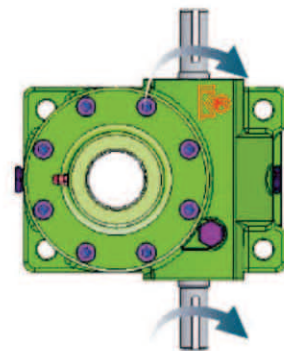

Rotation Direction

With Motor Flange (VJM Standard Type)

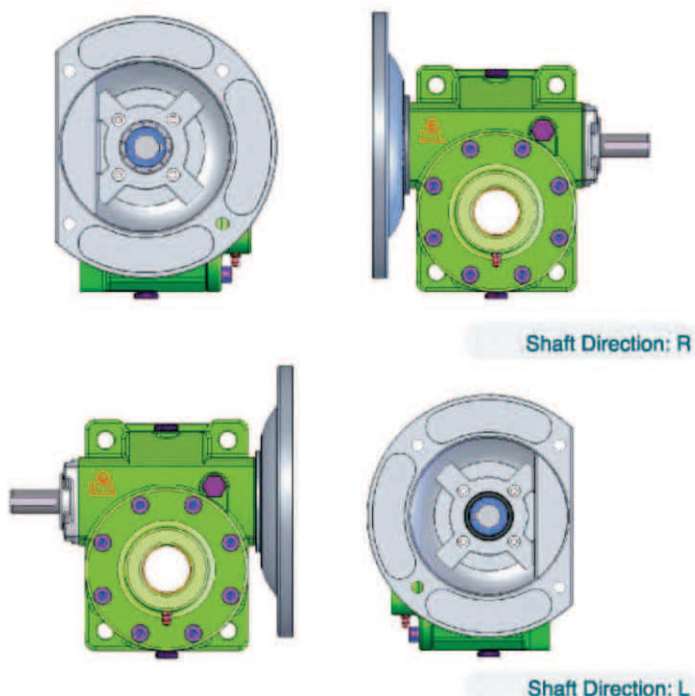

Shaft Direction: R

Shaft Direction: L



The Screw upward

■ LUBRICANT

To use appropriate lubricant will enhance the efficiency of the jack, and increase its service life. LI MING screw jacks use KUO-KUANG brand HD-150 lubricant.



螺旋升降器減速機系列

SCREW JACK REDUCER SERIES

特性FEATURES :

螺旋升降器結構主要為由機身、含內螺紋之銅件、螺桿及其它附件組成。在設計規範上從35#~80#，有多種規格。螺桿端在應用上又可分為全牙式、平頭式、螺牙式、栓孔式、頂板式。螺旋升降器具有體積小、功能多、重量輕、無噪音、結構緊湊、安裝方便、靈活、動力源廣、傳動效率高、使用壽命長等特點。可以頂升、降落、提升、下壓、推進、翻轉等多種安裝使用方式。螺旋升降器可單台或多台組合使用。能按一定的程式準確地控制調整頂升或降落的高度，可以用電機或其他動力直接帶動，也可以手動方式帶動。

The screw jack is composed of a main body, copper articles with interior thread, screw and other accessories. It comes in various specifications from model 35 to 80. In actual application, the screw ends can be divided into various types such as : no end, rod end, threaded end, clevis end, and top plate. The screw jack has a variety of features, such as compact size, multiple functions, light weight, no noise, intensified structure, convenient installation, high maneuverability, wide variety of power sources, high transmission efficiency, and long service life. It is capable of various installation, such as moving upward, moving downward, pushing forward, overturning, etc. The screw jacks can be used independently or in combination of several sets. It can accurately control lifting or lowering height according to programmed setting. It can be driven directly by electrical or other power sources, or by manually.

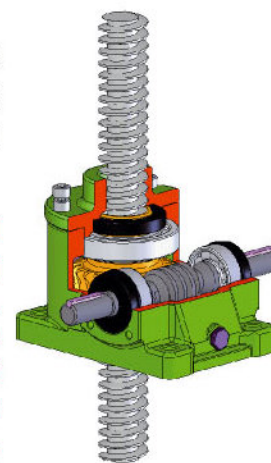

機種型號表示 INDICATION OF MODEL NUMBERS

LM - VJ - 50 - 10 - L - I -		A	-300				
公司代號 Company Code	機型 Type	型號 Model	速比 Ratio	軸向 Direction	馬力 Horse Power	螺桿型式 Screw End	長度 Length
	VJ	35			1/4HP	A (全牙式)NO END	300
	VJM	40			1/2HP	B (平頭式)ROD END	
		50			1HP	C (螺牙式)THREADED END	
		60			2HP	D (栓孔式)CLEVIS END	
		70			3HP	E (頂板式)TOP PLATE	
		80					

螺桿端型式 TYPE OF SCREW END

A 型式Type (全牙式) NO END	B 型式Type (平頭式) ROD END	C 型式Type (螺牙式) THREADED END	D 型式Type (栓孔式) CLEVIS END	E 型式Type (頂板式) TOP PLATE

容許彎曲負荷值

PERMISSIBLE BENDING LOAD

關於各種型號及軸端各種負荷方式，有關牙桿長度及容許彎曲負荷可參考以下表格或計算式。

Concerning the variety of models and loading methods at screw end, as well as screw length and permissible bending load, please refer to the following charts or formulae.

計算方法：formula

$$P_{cr} = n \cdot \pi^2 \cdot E \cdot (k / \ell)^2 \cdot A \cdot \alpha$$

n：軸端支撐因數

shaft end support factor

E：縱向彈性模數

longitudinal elasticity modulus

2.1x10 kgf/mm²

K：最小輔助半徑

Minimum auxiliary radius

$$K = \frac{d_1}{4}$$

d₁：螺紋底直徑

Minor diam

ℓ：軸支撐長度

shaft support length

A：舉升螺桿之螺紋底直徑的斷面積

Thread of lift screw

Section area of minor diam.

$$A = \frac{\pi \cdot (d_1)^2}{4}$$

α：安全係數

α=0.25

Safety factor

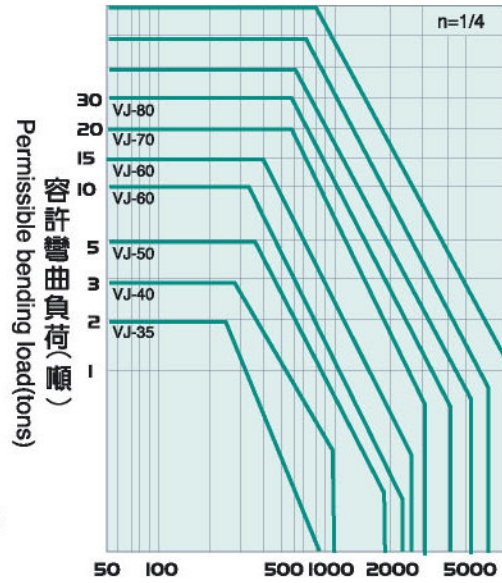
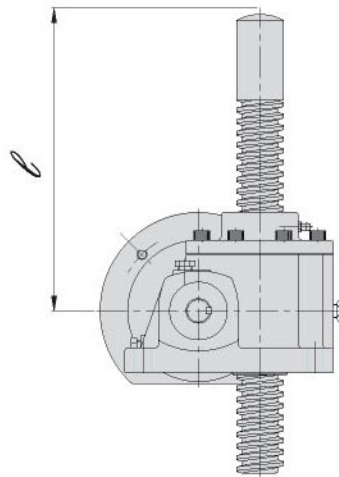

軸支撐長度 (mm)
Shaft support length(mm)
千斤頂固定-軸端游離
Jack fixed shaft terminal free

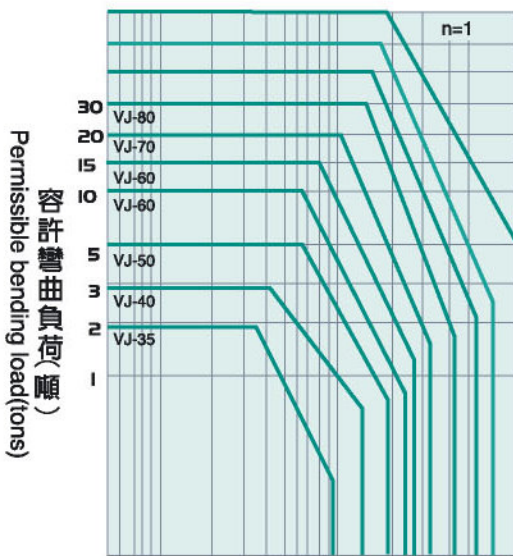

軸支撐長度 (mm)
Shaft support length(mm)
千斤頂支撐-軸端游離
(拴孔式) - (拴孔式)
Jack fixed shaft terminal support

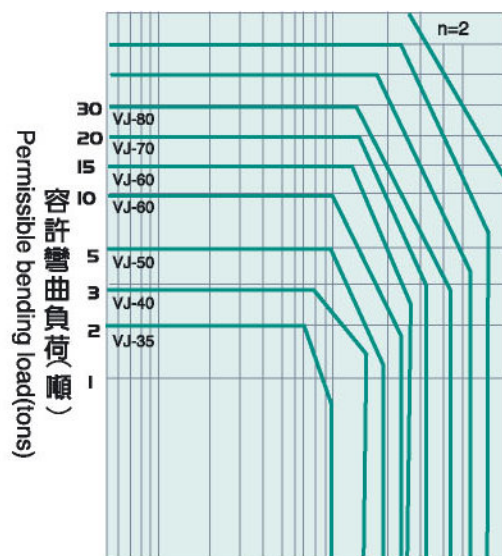

軸支撐長度 (mm)
Shaft support length(mm)
千斤頂固定-頂板固定
Jack fixed -top plate fixed



螺旋升降器減速機系列 SCREW JACK REDUCER SERIES

■ VJ(35#~50#)分解系統圖

■ SYSTEM DRAWING OF MODEL VJ(35#~50#)

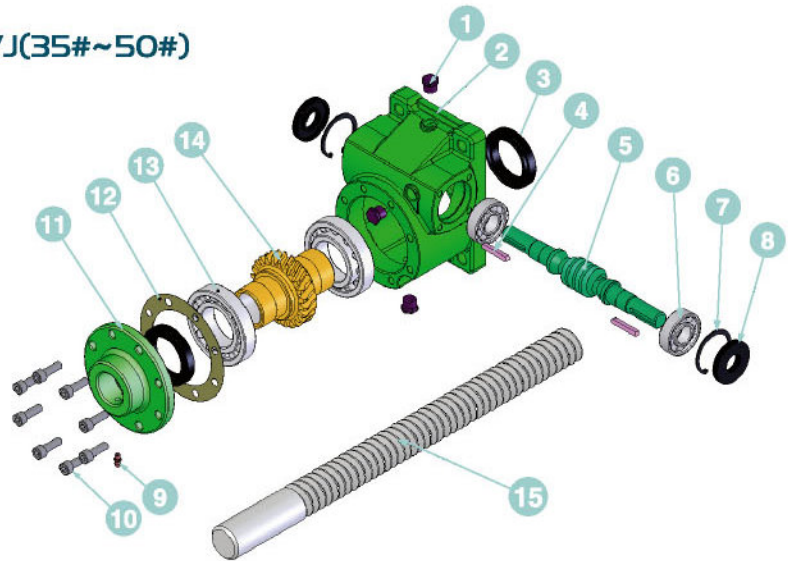

NO.	名稱	NAME OF PARTS	NO.	名稱	NAME OF PARTS
1	油栓	Oil Plug	9	牛油嘴	Fittings
2	蝸輪箱	Outer Shell	10	六角承窩頭螺絲	HEX. Screw
3	油封TC	Oil Seal TC	11	出力軸蓋	Output Shaft Cover
4	單圓鍵	Key	12	非石棉墊片	Paper Packing
5	蝸桿	Worm Shaft	13	滾錐軸承	Taper Roller Bearing
6	滾珠軸承	Ball Bearing	14	蝸輪	Worm wheel
7	R扣環	R Snap Ring	15	螺桿	Screw
8	油封SC	Oil Seal SC			

■ VJ(60#~80#)分解系統圖

■ SYSTEM DRAWING OF MODEL VJ(60#~80#)

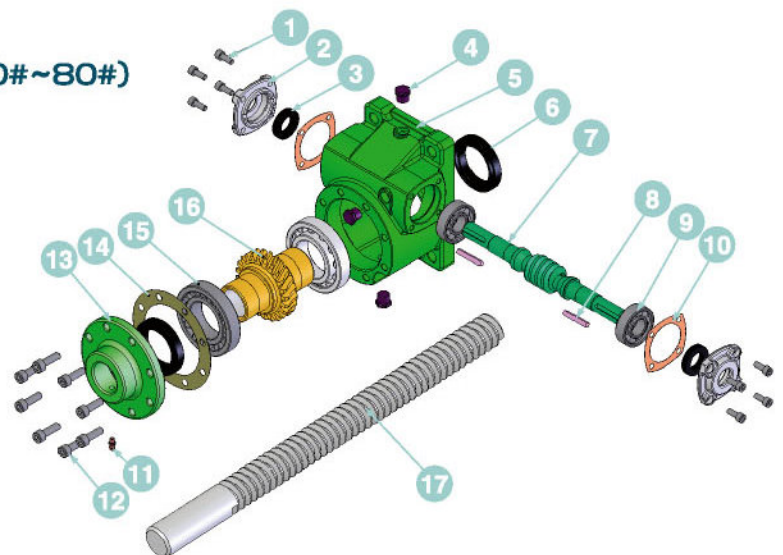

NO.	名稱	NAME OF PARTS	NO.	名稱	NAME OF PARTS
1	六角承窩頭螺絲	HEX. Screw	10	非石棉墊片	Paper Packing
2	入力軸蓋	Input Shaft Cover	11	牛油嘴	Fittings
3	油封SC	Oil Seal SC	12	六角承窩頭螺絲	HEX. Screw
4	油栓	Oil Plug	13	出力軸蓋	Output Shaft Cover
5	蝸輪箱	Outer Shell	14	非石棉墊片	Paper Packing
6	油封TC	Oil Seal TC	15	滾錐軸承	Taper Roller Bearing
7	蝸桿	Worm Shaft	16	蝸輪	Worm wheel
8	單圓鍵	Key	17	螺桿	Screw
9	滾珠軸承 (60#、70#)	Ball Bearing (60#、70#)			
	滾錐軸承 (80#)	Taper Roller Bearing (80#)			

■ 減速機參數

■ PARAMETER OF SCREW JACK REDUCER

型號 MODEL	螺桿 SCREW Ø	螺距 PITCH mm	減速比 RATIO	1800RPM 入力轉速INPUT SPEED				1500RPM 入力轉速INPUT SPEED				1200RPM 入力轉速INPUT SPEED			
				最大 輸入馬力 MAX.INPUT HP	輸出轉速 OUTPUT SPEED RPM	荷重 LOAD (KG)	每分鐘升 (降) MM/MIN	最大 輸入馬力 MAX.INPUT HP	輸出轉速 OUTPUT SPEED RPM	荷重 LOAD (KG)	每分鐘升 (降) MM/MIN	最大 輸入馬力 MAX.INPUT HP	輸出轉速 OUTPUT SPEED RPM	荷重 LOAD (KG)	每分鐘升 (降) MM/MIN
35	1"	P=5	5	0.93	360	500	1800	0.86	300	550	1500	0.87	240	700	1200
			10	0.50	180	500	900	0.50	150	550	750	0.50	120	700	600
			20	0.50	90	600	450	0.50	75	700	375	0.50	60	900	300
40	1 1/4"	P=6	6	1.31	300	700	1800	1.25	250	800	1500	1.18	200	950	1200
			12	0.89	150	950	900	0.86	125	1100	750	0.81	100	1300	600
			24	0.50	75	950	450	0.50	63	1100	375	0.50	50	1300	300
50	1 1/2"	P=6	6	1.86	300	900	1800	1.72	250	1000	1500	1.66	200	1200	1200
			12	1.47	150	1350	900	1.36	125	1500	750	1.31	100	1800	600
			24	1.04	75	1800	450	0.96	63	2000	375	0.92	50	2400	300
60	2"	P=8	8	2.84	225	1300	1800	2.64	188	1450	1500	2.48	150	1700	1200
			16	1.50	113	1300	900	1.40	94	1450	750	1.31	75	1700	600
			32	1.07	56	1750	450	1.00	47	1950	375	0.92	37	2250	300
70	2 1/2"	P=10	10	3.57	180	1400	1800	3.24	150	1850	1500	3.01	120	1950	1200
			20	1.90	90	1600	900	1.97	75	1850	750	1.84	60	2250	600
			40	1.53	45	2400	450	1.57	38	2800	375	1.46	30	3350	300
80	75mm	P=12	12	4.86	150	1850	1800	4.71	125	2150	1500	4.55	100	2600	1200
			18	3.56	100	1900	1200	3.59	83	2300	1000	3.44	66	2750	800
			36	2.22	50	2200	600	2.19	42	2600	500	2.15	33	3200	400

型號 MODEL	螺桿 SCREW Ø	螺距 PITCH mm	減速比 RATIO	900RPM 入力轉速INPUT SPEED				600RPM 入力轉速INPUT SPEED				300RPM 入力轉速INPUT SPEED			
				最大 輸入馬力 MAX.INPUT HP	輸出轉速 OUTPUT SPEED RPM	荷重 LOAD (KG)	每分鐘升 (降) MM/MIN	最大 輸入馬力 MAX.INPUT HP	輸出轉速 OUTPUT SPEED RPM	荷重 LOAD (KG)	每分鐘升 (降) MM/MIN	最大 輸入馬力 MAX.INPUT HP	輸出轉速 OUTPUT SPEED RPM	荷重 LOAD (KG)	每分鐘升 (降) MM/MIN
35	1"	P=5	5	0.84	180	900	900	0.62	120	1000	600	0.50	60	1000	300
			10	0.50	90	750	450	0.50	60	1000	300	0.25	30	1350	150
			20	0.50	45	1200	225	0.25	30	1350	150	0.25	15	1350	75
40	1 1/4"	P=6	6	1.22	150	1300	900	1.12	100	1800	600	0.56	20	1800	300
			12	0.77	75	1650	450	0.62	50	2000	300	0.50	25	2000	150
			24	0.50	38	1650	225	0.50	25	2000	150	0.25	13	2000	75
50	1 1/2"	P=6	6	1.55	150	1500	900	1.17	100	1700	600	0.72	50	2100	300
			12	1.17	75	2150	450	0.78	50	2150	300	0.50	25	2500	150
			24	0.73	38	2550	225	0.56	25	2900	150	0.50	13	2850	75
60	2"	P=8	8	2.30	113	2100	900	2.22	75	3050	600	1.75	38	4800	300
			16	1.27	56	2200	450	1.17	38	3050	300	0.92	19	4800	150
			32	0.86	28	2800	225	0.84	19	4100	150	0.65	9	6400	75
70	2 1/2"	P=10	10	2.84	90	2450	900	2.59	60	3350	600	1.89	30	4900	300
			20	1.72	45	2800	450	1.58	30	3850	300	1.15	15	5600	150
			40	1.44	23	4400	225	1.25	15	5750	150	0.92	8	8400	75
80	75mm	P=12	12	4.27	75	3250	900	3.94	30	4500	600	2.80	25	6400	300
			18	3.28	50	3500	600	2.94	33	4700	400	2.09	17	6700	200
			36	1.97	25	3900	300	1.82	17	5400	200	1.61	8	9600	100

MODEL : VJ



使用前須注入黃油(潤滑螺桿)

To oil grease before operate (lubrication the screw)

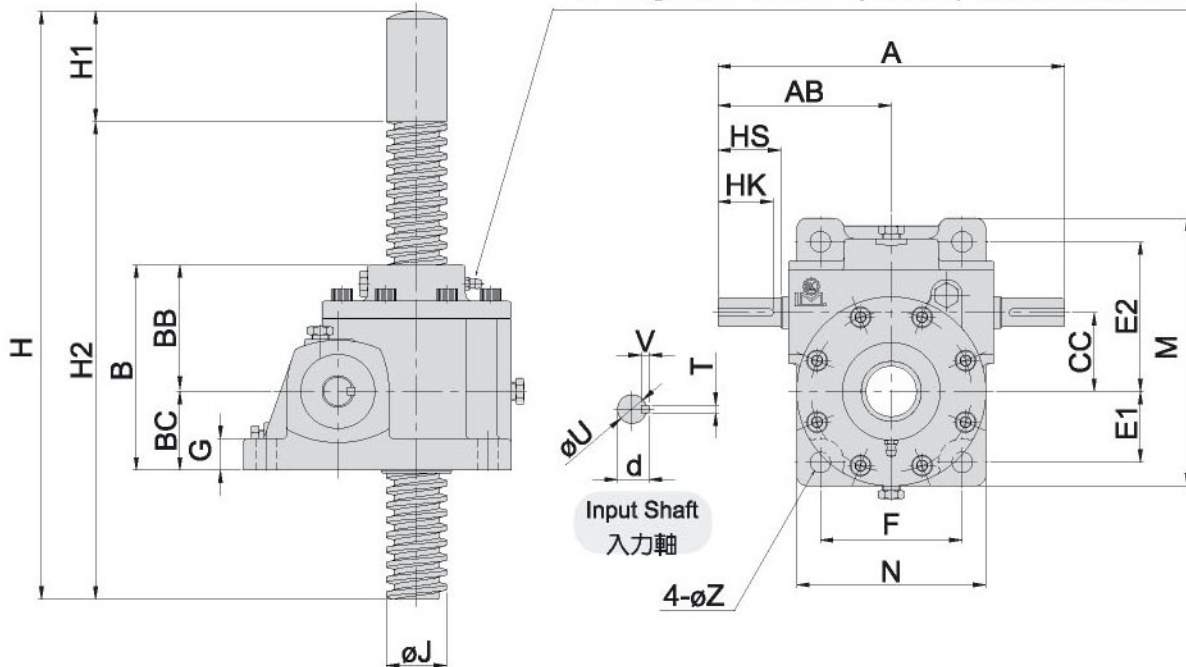

註一：請參考螺桿端尺寸表

註二：行程=H-H1-B

Note1: Please refer to dimension of screw end.

Note 2: Route=H-H1-B

尺寸表 Dimension

單位：m/m

型號 MODEL	減速比 RATIO	馬力 HP	A	AB	B	BB	BC	CC	腳座 FOOT STOCK					輸入軸 INPUT SHAFT				øJ 螺桿 SCREW	螺距 PITCH	H1 註一 NOTE1	重量 WEIGHT (KG)		
									E1	E2	F	M	N	G	Z	HS	U					d	TxVxHK
35	5	1/4	170	85	110	70	40	35	38	73	66	135	90	16	11	30	15	17	5x5x25	1"	P=5	50	4.1
	10	1/2																					
40	6	1/4	220	110	130	80	50	40	42	83	80	155	110	18	11	40	18	20	5x5x35	1 1/4"	P=6	60	7.5
	12	1/2																					
50	6	1/2	220	110	130	80	50	50	45	95	90	170	120	20	13	40	18	20	5x5x35	1 1/2"	P=6	70	9
	12	1																					
60	8	1	278	139	160	100	60	60	70	120	110	230	148	22	17	45	25	28	7x7x40	2"	P=8	70	16
	16	2																					
70	10	1	318	159	180	110	70	70	75	135	140	250	178	25	17	50	28	31	7x7x45	2 1/2"	P=10	80	26
	20	2																					
80	12	2	360	180	210	130	80	80	90	155	160	295	210	28	21	50	28	31	7x7x45	75mm	P=12	80	45
	18	3																					
	36																						



螺旋升降器減速機系列 SCREW JACK REDUCER SERIES

MODEL : VJM



使用前須注入黃油(潤滑螺桿)

To oil grease before operate (lubrication the screw)

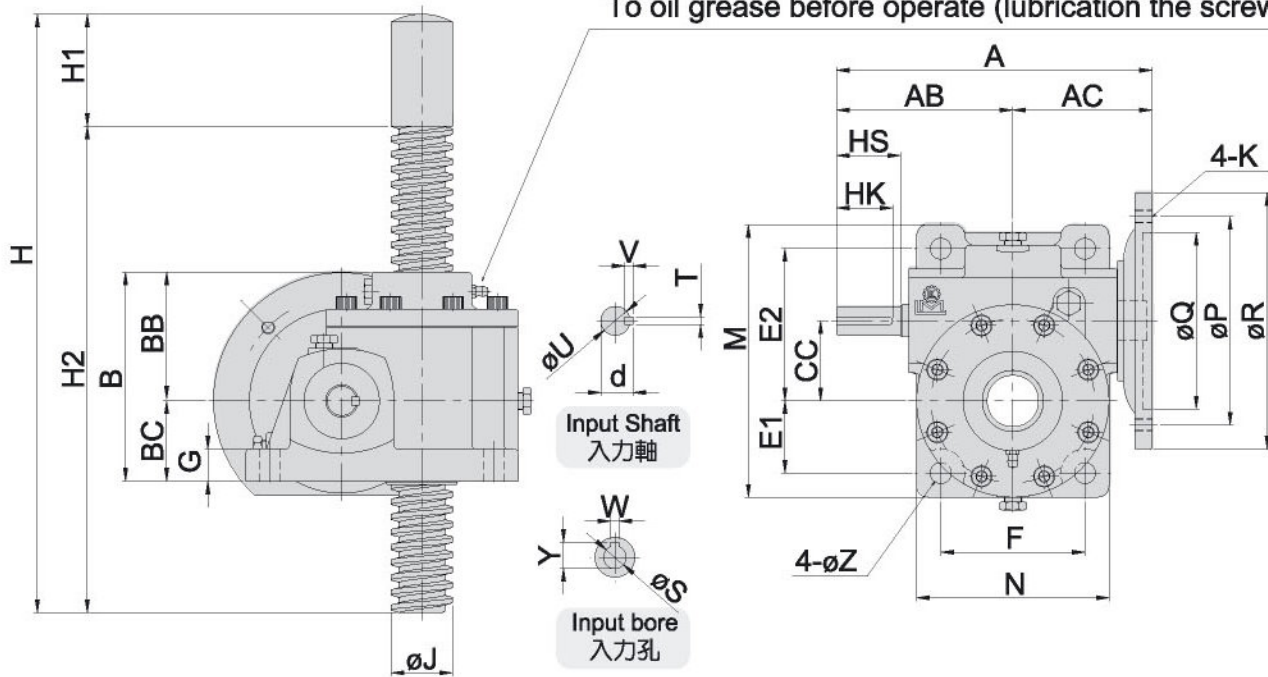

註一：請參考螺桿端尺寸表

註二：行程=H-H1-B

Note1: Please refer to dimension of screw end.

Note 2: Route=H-H1-B

尺寸表 Dimension

單位：m/m

型號 MODEL	減速比 RATIO	馬力 HP	A	AB	AC	B	BB	BC	CC	馬達盤 MOTOR FLANGE				腳座 FOOT STOCK				入力孔 INPUT SHAFT				入力孔 INPUT BORE			ØJ 螺桿 SCREW	螺距 PITCH	H1 註一 NOTE1	重量 WEIGHT (KG)			
										P	Q	R	K	E1	E2	F	M	N	G	Z	HS	U	d	TxV					X	HK	W
35	5	1/4	167	95.3	72	110	70	40	35	130	110	160	M8	38	73	66	135	90	16	11	31	15	17	5x5x25	5	127	11	1"	P=5	50	4.1
	10	1/2								165	130	200	M10	45	95	90	170	120	20	13	40	18	20	5x5x35	5	163	14				
40	6	1/4	196	110	86	130	80	50	40	130	110	160	M8	42	83	80	155	110	18	11	40	18	20	5x5x35	5	127	11	1 1/4"	P=6	60	7.5
	12	1/2								165	130	200	M10	45	95	90	170	120	20	13	40	18	20	5x5x35	5	163	14				
50	6	1/2	197	110	87	130	80	50	50	130	110	160	M8	45	95	90	170	120	20	13	40	18	20	5x5x35	5	163	14	1 1/2"	P=6	70	9
	12	1								165	130	200	M10	45	95	90	170	120	20	13	40	18	20	5x5x35	5	163	14				
60	8	1	242	139	103	160	100	60	60	165	130	200	M10	70	120	110	230	148	22	17	45	25	28	7x7x40	6	218	19	2"	P=8	70	16
	16	2								165	130	200	M10	70	120	110	230	148	22	17	45	25	28	7x7x40	6	218	19				
70	10	1	277	159	118	180	110	70	70	165	130	200	M10	75	135	140	250	178	25	17	50	28	31	7x7x45	6	218	19	2 1/2"	P=10	80	26
	20	2								165	130	200	M10	75	135	140	250	178	25	17	50	28	31	7x7x45	6	218	19				
80	12	2	319	180	319	210	130	80	80	165	130	200	M10	90	155	160	295	210	28	21	50	28	31	7x7x45	8	273	24	75mm	P=12	80	45
	18	3								165	130	200	M10	90	155	160	295	210	28	21	50	28	31	7x7x45	8	273	24				
	36									215	180	250	M12																		

■ 螺桿端尺寸

■ DIMENSION OF SCREW END

A型式TYPE		B型式TYPE		型號/代號MODEL	ØJ	H1				
				35	1"	50				
				40	1 1/4"	60				
				50	1 1/2"	70				
				60	2"	70				
				70	2 1/2"	80				
				80	75mm	80				
C型式TYPE		D型式TYPE		型號/代號MODEL	ØJ	A	ØB	H1	M*P	
				35	1"	40	20	50	M20*P1.0	
				40	1 1/4"	50	25	60	M25*P1.5	
				50	1 1/2"	50	30	70	M30*P1.5	
				60	2"	60	40	70	M40*P1.5	
				70	2 1/2"	70	50	80	M50*P1.5	
				80	75mm	75	60	80	M60*P2.0	
E型式TYPE		E型式TYPE		型號/代號MODEL	ØJ	A	B	H1	ØD	PCD
				35	1"	84	10	50	11	60
				40	1 1/4"	84	10	60	11	60
				50	1 1/2"	99	13	70	13	75
				60	2"	118	15	70	15	90
				70	2 1/2"	138	21	80	17	105
				80	75mm	158	25	80	21	120

■ 螺桿長度

■ LENGTH OF THE SCREW

螺桿直徑 SCREW DIA. ØJ	螺桿牙距 PITCH P(mm)	螺桿長度Length of the Screw m/m H (標準螺桿長度，亦可訂製其他尺寸) (Standard length of the screw, other dimension also available)							
1"	5	400	—	600	800	1000	1200	1500	2000
1 1/4"	6	400	—	600	800	1000	1200	1500	2000
1 1/2"	6	400	—	600	800	1000	1200	1500	2000
2"	8	—	500	600	800	1000	1200	1500	2000
2 1/2"	10	—	—	600	800	1000	1200	1500	2000
75m/m	12	—	—	600	800	1000	1200	1500	2000

此尺寸需另訂購