

# SERVOBOX

## MODEL : SDL

1-Stage / Kademe

RATIO / ÇEVİRİM : 4, 5, 7, 10, 14, 20

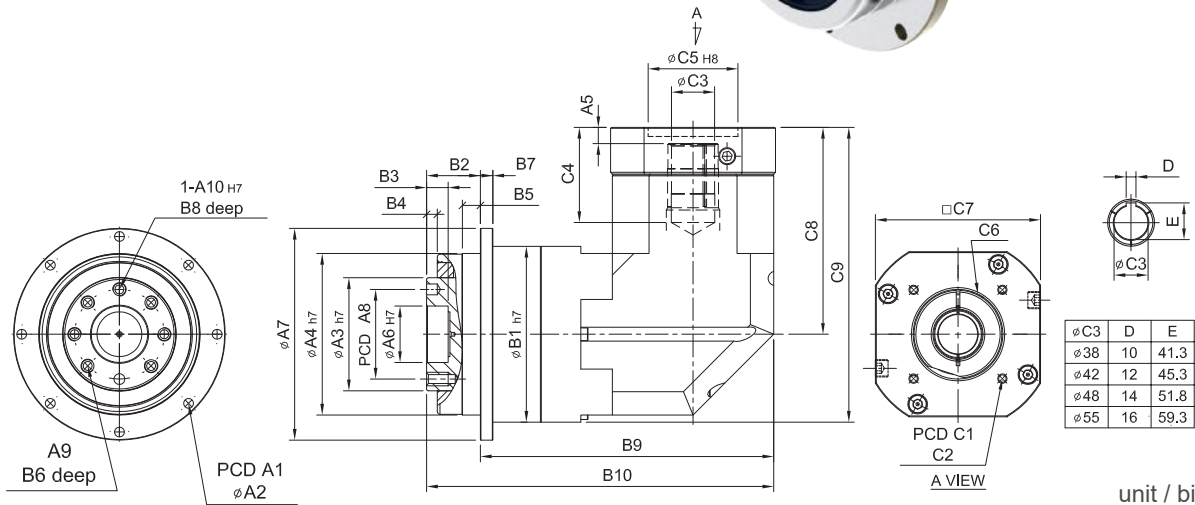
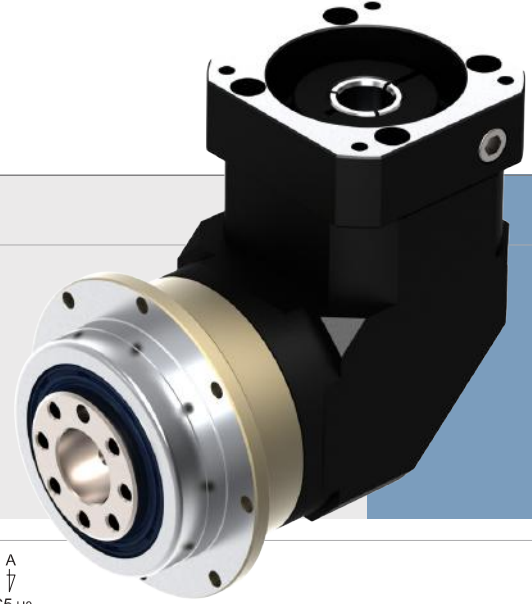

unit / birim: mm

Model Code	47	64	90	110	140	200	255
A1	67	79	109	135	168	233	280
A2	8-3.4	8-4.5	8-5.5	8-5.5	12-6.6	12-9.0	16-13.5
A3	28	40	63	80	100	160	180
A4	47	64	90	110	140	200	255
A5	6	6	9-23.5	10-20	10	12.5-14.5	12.5-14.5
A6	12	20	31.5	40	50	80	100
A7	72	86	118	146	179	248	300
A8	20	31.5	50	63	80	125	140
A9	4 - M3 x P0.5	7 - M5 x P0.8	7 - M6 x P1.0	11 - M6 x P1.0	11 - M8 x P1.25	11 - M10 x P1.5	12 - M16 x P2.0
A10	3	5	6	6	8	10	12
B1	59	70	98	125	156	212	255
B2	19.5	19.5	30	29	38	50	66
B3	5	7	12	12	12	16	20
B4	1.5	4	6	6	6	8	12
B5	5	6	10	10	15	15	20
B6	6.5	8	12	12	16	22	32
B7	4	5	7	8	10	12	18
B8	4	6	6	7	7	10	10
B9	84.2	105.5	163.6	203	227.5	313	332.5
B10	103.7	125	193.6	232	265.5	363	398.5
C1	46-60-63	70-75-90	90-110-115-145	115-145-165	145-165-200	200-215-265	200-265-300
C2	M3-M4-M5	M4-M5-M6	M5-M6-M8	M6-M8-M10	M8-M10-M12	M10-M12-M16	M12-M16
C3	8-9-11	14-19	19-22-24	24-28-32	32-35-38	38-42-48-55	42-48-55
C4	27	33.5-41.5	53-67.5	67-77	85	132-134	132-134
C5	30-40-50	50-60-70	70-80-95-110	95-110-130	110-130-180	114.3-180-230	220-250-265
C6	M4 x P0.7	M5 x P0.8	M6 x P1.0	M8 x P1.25	M10 x P1.5	M10 x P1.5	M10 x P1.5
C7	46-55	64-70-80	92-110-130	122-130-150	146-150-190	182-200-250	222-250-265
C8	61	77-85	115.3-129.8	141-151	165.7	235-237	235-273
C9	90.5	112-120	164.3-178.8	203.5-213.5	243.7	341-343	362-364

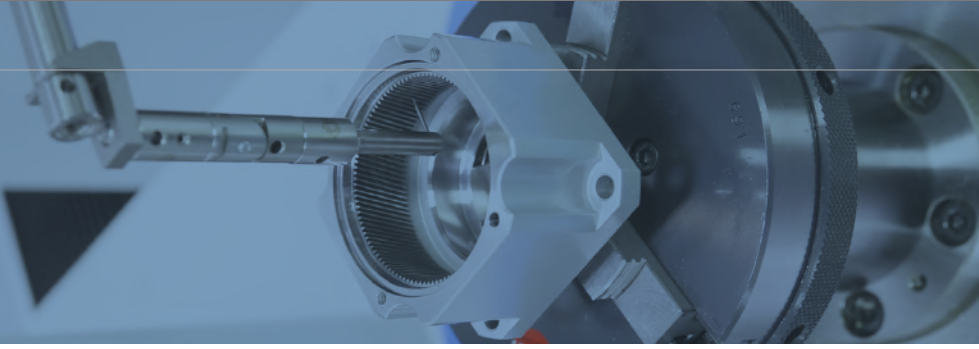

Model No.		Unit/Birim	Ratio Çevrim	47	64	90	110	140	200	255
Nominal output torque / Nominal Çıkış Torku	$T_{2N}$	Nm	4	22	60	160	335	650	1,200	2,020
			5	20	50	155	333	618	1,189	2,010
			7	19	47	142	309	573	1,108	1,870
			10	20	50	136	294	549	1,059	1,779
			14	19	47	142	309	573	1,108	1,870
			20	16	43	136	294	549	1,059	1,779
Max. Acceleration Torque / Max. İvmelenme Torku	$T_{2B}$	Nm	4 ~ 20	1.8 Times of Rated Output Torque / 1,8 x Nominal Çıkış Torku						
Max. Output Torque / Max. Çıkış Torku	$T_{2NOT}$	Nm	4 ~ 20	3 Times of Rated Output Torque / 3 x Nominal Çıkış Torku						
Rated Input Speed / Nominal Giriş Devri	$n_{IN}$	rpm	4 ~ 20	3,000	3,000	3,000	3,000	3,000	3,000	2,000
Max. Input Speed / Max. Giriş Devri	$n_{IB}$	rpm	4 ~ 20	6,000	6,000	6,000	6,000	5,000	4,000	3,000
Backlash P <sub>s</sub> / Min. Boşluk Oranı		arcmin	4 ~ 20	-	-	≤ 2	≤ 2	≤ 2	≤ 2	≤ 2
Backlash P <sub>0</sub> / Düşük Boşluk Oranı		arcmin	4 ~ 20	≤ 4	≤ 4	≤ 4	≤ 4	≤ 4	≤ 4	≤ 4
Backlash P <sub>1</sub> / Azaltılmış Boşluk Oranı		arcmin	4 ~ 20	≤ 6	≤ 6	≤ 6	≤ 6	≤ 6	≤ 6	≤ 6
Backlash P <sub>2</sub> / Standart Boşluk Oranı		arcmin	4 ~ 20	≤ 8	≤ 8	≤ 8	≤ 8	≤ 8	≤ 8	≤ 8
Torsional Rigidity / Burulma Direnci		Nm/arcmin	4 ~ 20	6	14	30	86	155	450	1,126
Max. Axial Force Ball Bearing / Max. Aksiyel Yük bilyalı Rulman	$F_{2rB}$	N	4 ~ 20	1,020	1,260	4,230	6,360	7,035	17,600	19,800
Max. Axial Force Taper Bearing / Max. Aksiyel Yük Masuralı Rulman	$F_{2aB}$	N	4 ~ 20	-	-	7,330	11,500	18,600	36,800	53,600
Service Life / Hizmet Ömrü	$L_H$	hr	4 ~ 20	S5 Döngüsel Çalışma: >30,000 (S1 Sürekli Çalışma: >15,000 saat) S5 Cycle Operation: >30,000 (S1 Continuous Operation: >15,000 hrs)						
Efficiency / Verim	$\eta$	%	4 ~ 20	≥ 95						
Operating Temperature / Çalışma Sıcaklığı		°C	4 ~ 20	- 25° C ~ + 90° C						
Lubrication / Yağlama			4 ~ 20	Synthetic Grease / Sentetik Gres						
Protection Class / Koruma Sınıfı			4 ~ 20	IP65						
Mounting Position / Montaj Pozisyonu			4 ~ 20	Any / Her Yönde						
Noise Level / Ses Seviyesi		dB	4 ~ 20	≤ 61	≤ 63	≤ 65	≤ 68	≤ 70	≤ 72	≤ 74
Weight / Ağırlık ±3%		Kg	4 ~ 20	1.1	2.3	6.9	13.4	23		

#### ■ Mass Moments of Inertia / Atalet Ağırlık Momenti (kg.cm<sup>2</sup>)

Ratio / Çevrim	47	64	90	110	140	200	255
4	0.09	0.36	2.28	6.85	23.5	68.1	134.8
5	0.09	0.36	2.28	6.85	23.5	68.1	134.8
7	0.09	0.36	2.28	6.85	23.5	68.1	134.8
10	0.09	0.36	2.28	6.85	23.5	68.1	134.8
14	0.03	0.08	1.88	6.2	21.8	66.5	120.2
20	0.03	0.08	1.88	6.2	21.8	66.3	118.8

# SERVOBOX

## MODEL : SDL

2-Stage / Kademe

RATIO / ÇEVİRİM : 20, 25, 35, 40, 50, 70, 100, 140, 200

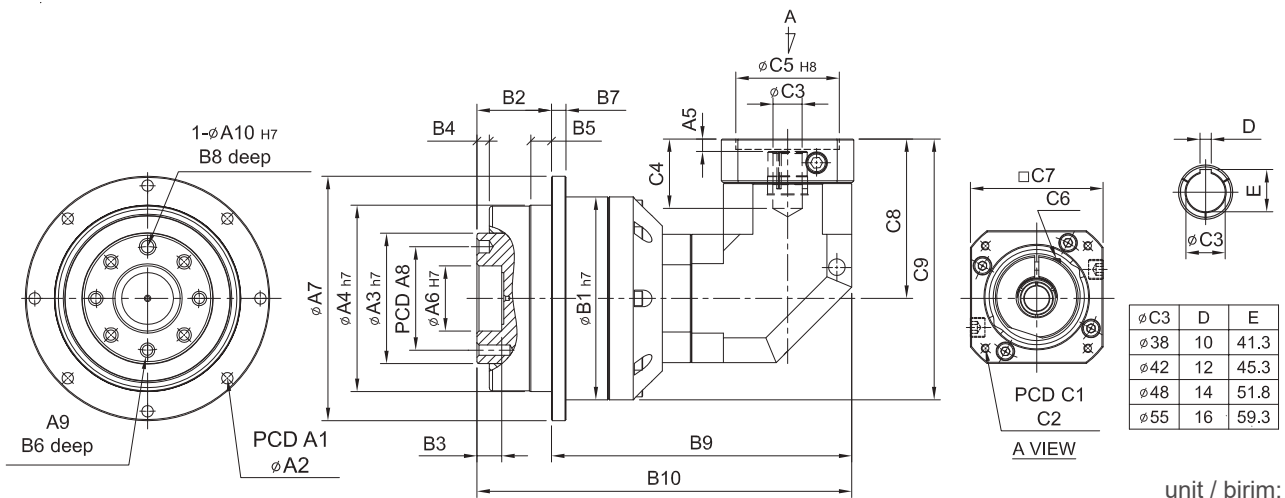
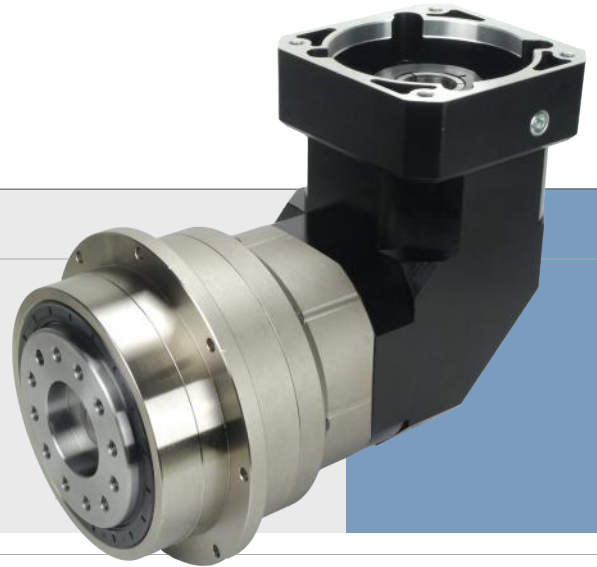

unit / birim: mm

Model Code	47	64	90	110	140	200	255
<b>A</b>							
A1	67	79	109	135	168	233	280
A2	8-3.4	8-4.5	8-5.5	8-5.5	12-6.6	12-9.0	16-13.5
A3	28	40	63	80	100	160	180
A4	47	64	90	110	140	200	255
A5	6	6	9-23	9-23.5	10	12.5	12.5-14.5
A6	12	20	31.5	40	50	80	100
A7	72	86	118	146	179	248	300
A8	20	31.5	50	63	80	125	140
A9	4 - M3 x P0.5	7 - M5 x P0.8	7 - M6 x P1.0	11 - M6 x P1.0	11 - M8 x P1.25	11 - M10 x P1.5	12 - M16 x P2.0
A10	3	5	6	6	8	10	12
<b>B</b>							
B1	59	70	98	125	156	212	255
B2	19.5	19.5	30	29	38	50	66
B3	5	7	12	12	12	16	20
B4	1.5	4	6	6	6	8	12
B5	5	6	10	10	15	15	20
B6	6.5	8	12	12	16	22	32
B7	4	5	7	8	10	12	16
B8	4	6	6	7	7	10	10
B9	110.2	118.5	151	210.6	254.5	308.5	379.1
B10	129.7	138	181	239.6	292.5	358.5	445.1
<b>C</b>							
C1	46-60-63	46-60-63	70-75-90	90-110-115-145	115-145-165	145-165-200	200-215-265
C2	M3-M4-M5	M3-M4-M5	M4-M5-M6	M5-M6-M8-M10	M6-M8-M10	M8-M10-M12	M10-M12-M16
C3	8-9-11	8-9-11	14-19	19-22-24	24-28-32	32-35-38	38-42-48-55
C4	27	27	33.5-41.5	53-67.5	67-77	85	117-119
C5	30-40-50	30-40-50	50-60-70	70-80-95-110	95-110-130	110-130-180	114.3-180-230
C6	M4 x P0.7	M4 x P0.7	M5 x P0.8	M6 x P1.0	M8 x P1.25	M10 x P1.5	M10 x P1.5
C7	46-55	46-55	64-70-80	92-110-130	122-130-150	146-150-190	182-200-250
C8	61	61	77-85	115.3-129.8	141-151	165.7	235-237
C9	90.5	96	126-134	177.8-192.3	219-229	271.7	362.5-364.5

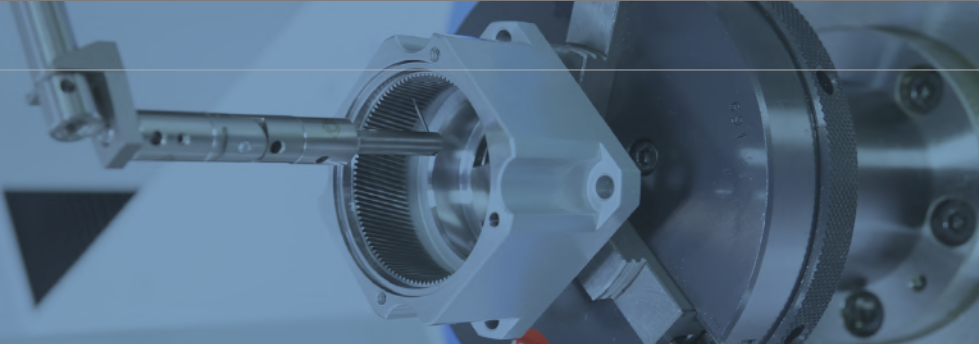

Model No.		Unit/Birim	Ratio Çevrim	47	64	90	110	140	200	255
Nominal output torque / Nominal Çıkış Torku	$T_{2N}$	Nm	20	22	60	160	335	650	1,200	2,020
			25	20	50	155	333	618	1,189	2,010
			35	19	47	142	309	573	1,108	1,870
			40	22	60	160	335	650	1,200	2,020
			50	20	50	155	333	618	1,189	2,010
			70	19	47	142	309	573	1,108	1,870
			100	16	43	136	294	549	1,059	1,779
			140	19	47	142	309	573	1,108	1,870
200	16	43	136	294	549	1,059	1,779			
Max. Acceleration Torque / Max. İvmelenme Torku	$T_{2B}$	Nm	20 ~ 200	1.8 Times of Rated Output Torque / 1,8 x Nominal Çıkış Torku						
Max. Output Torque / Max. Çıkış Torku	$T_{2NOT}$	Nm	20 ~ 200	3 Times of Rated Output Torque / 3 x Nominal Çıkış Torku						
Rated Input Speed / Nominal Giriş Devri	$n_{1N}$	rpm	20 ~ 200	3,000	3,000	3,000	3,000	3,000	3,000	2,000
Max. Input Speed / Max. Giriş Devri	$n_{1B}$	rpm	20 ~ 200	6,000	6,000	6,000	6,000	6,000	4,000	3,000
Backlash P <sub>s</sub> / Min. Boşluk Oranı		arcmin	20 ~ 200	-	-	-	≤ 4	≤ 4	≤ 4	≤ 4
Backlash P <sub>0</sub> / Düşük Boşluk Oranı		arcmin	20 ~ 200	≤ 7	≤ 7	≤ 7	≤ 7	≤ 7	≤ 7	≤ 7
Backlash P <sub>1</sub> / Azaltılmış Boşluk Oranı		arcmin	20 ~ 200	≤ 9	≤ 9	≤ 9	≤ 9	≤ 9	≤ 9	≤ 9
Backlash P <sub>2</sub> / Standart Boşluk Oranı		arcmin	20 ~ 200	≤ 12	≤ 12	≤ 12	≤ 12	≤ 12	≤ 12	≤ 12
Torsional Rigidity / Burulma Direnci		Nm/arcmin	20 ~ 200	6	14	30	86	155	450	1,126
Max. Axial Force Ball Bearing / Max. Aksiyel Yük Biyalı Rulman	$F_{2tB}$	N	20 ~ 200	1,020	1,260	4,230	6,360	7,035	17,600	19,800
Max. Axial Force Taper Bearing / Max. Aksiyel Yük Masuralı Rulman	$F_{2tAB}$	N	20 ~ 200	-	-	7,330	11,500	18,600	36,800	53,600
Service Life / Hizmet Ömrü	$L_H$	hr	20 ~ 200	S5 Döngüsel Çalışma: >30,000 (S1 Sürekli Çalışma: >15,000 saat) S5 Cycle Operation: >30,000 (S1 Continuous Operation: >15,000 hrs)						
Efficiency / Verim	$\eta$	%	20 ~ 200	≥ 92						
Operating Temperature / Çalışma Sıcaklığı		°C	20 ~ 200	- 25° C ~ + 90° C						
Lubrication / Yağlama			20 ~ 200	Synthetic Grease / Sentetik Gres						
Protection Class / Koruma Sınıfı			20 ~ 200	IP65						
Mounting Position / Montaj Pozisyonu			20 ~ 200	Any / Her Yönde						
Noise Level / Ses Seviyesi		dB	20 ~ 200	≤ 56	≤ 58	≤ 60	≤ 63	≤ 65	≤ 67	≤ 70
Weight / Ağırlık ±3%		Kg	20 ~ 200		2	6	11.8	22.3	48.5	

#### ■ Mass Moments of Inertia / Atalet Ağırlık Momenti (kg.cm<sup>2</sup>)

Ratio / Çevrim	47	64	90	110	140	200	255
20	0.09	0.36	2.28	6.85	23.5	22.8	68.2
25	0.09	0.36	2.28	6.85	23.5	22.8	68.2
35	0.09	0.36	2.28	6.85	23.5	22.8	68.2
40	0.09	0.36	2.28	6.85	23.5	22.8	68.2
50	0.09	0.36	2.28	6.85	23.5	22.8	68.2
70	0.09	0.36	2.28	6.85	23.5	22.8	68.2
100	0.09	0.36	2.28	6.85	23.5	22.8	68.2
140	0.03	0.08	1.88	6.2	21.8	21.1	64.9
200	0.03	0.08	1.88	6.2	21.8	21.1	64.9