

MODEL : FE

RATIO / ÇEVİRİM : 3, 4, 5, 7, 10 (1-Stage / Kademe)

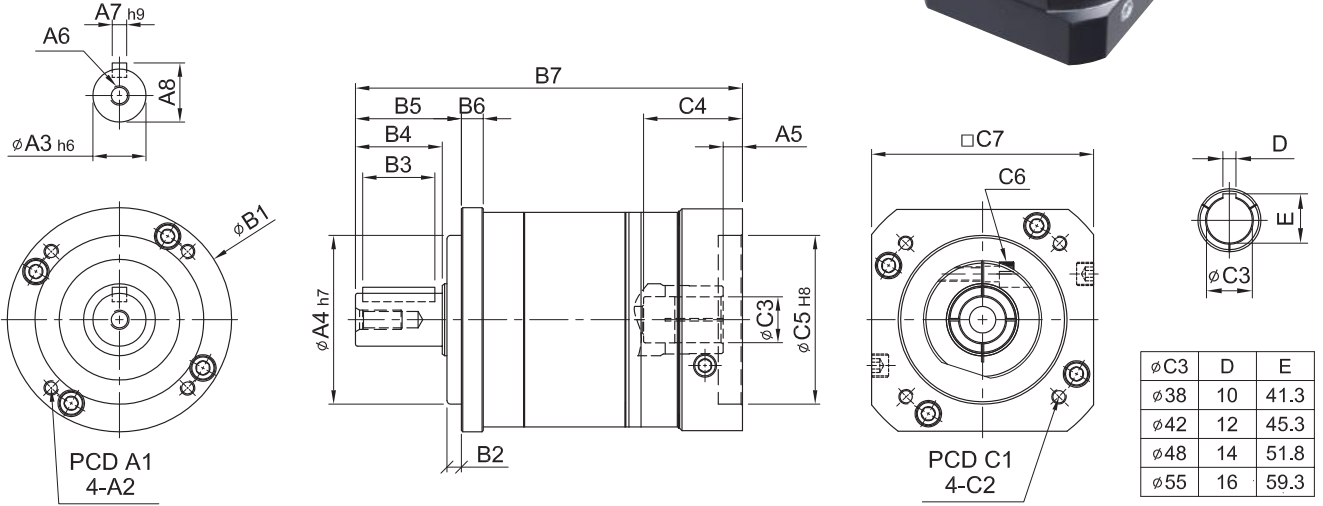

unit / birim : mm

Model Code	50	70	90	120	145	180	220	
A	A1	42	60	80	105	130	184	218
	A2	M4 x P0.7	M5 x P0.8	M6 x P1.0	M8 x P1.25	M10 x P1.5	M12 x P1.75	M16 x P2.0
	A3	13	16	22	32	40	55	75
	A4	35	50	70	90	110	160	180
	A5	5	6	9 · 23.5	10 · 20	10	13 · 15	13.5 · 15.5
	A6	M4 x P0.7	M5 x P0.8	M8 x P1.25	M10 x P1.5	M12 x P1.75	M14 x P2.0	M16 x P2.0
	A7	5	5	6	10	12	16	20
	A8	15	18	24.5	35	43	59	79.5
B	B1	Ø50	Ø70	Ø93	Ø122	Ø148	Ø205	Ø242
	B2	4	5	6	8	10	20	20
	B3	15	20	30	40	65	70	90
	B4	20	28	36	50	74	82	104
	B5	25	34	44	60	87	106	129
	B6	6	8	9	12	15	21.5	30
	B7	100.5	132.5 · 140.5	170.5 · 185	227.5 · 237.5	291	325 · 327	376.5 · 378.5
C	C1	46 · 60 · 63	70 · 75 · 90	90 · 100 · 115 · 145	115 · 145 · 165	145 · 165 · 200	200 · 215 · 265	200 · 265 · 300
	C2	M3 M4 M5	M4 M5 M6	M5 M6 M8	M6 M8 M10	M8 M10 M12	M10 M12	M12 M16
	C3	8 · 9 · 11	14 · 19	19 · 22 · 24	24 · 28 · 32	35 · 38	38 · 42 · 48	42 · 48 · 55
	C4	26	33.5	51 · 65.5	63 · 73	81.5	115 · 117	118 · 120
	C5	30 · 40 · 50	40 · 50 · 60	70 · 80 · 95 · 110	95 · 110 · 130	110 · 130 · 180	114.3 · 180 · 230	114.3 · 230 · 250
	C6	M4 x P0.7	M5 x P0.8	M6 x P1.0	M8 x P1.25	M10 x P1.5	M10 x P1.5	M10 x P1.5
	C7	46 · 55	64 · 70 · 80	92 · 110 · 130	122 · 130 · 150	146 · 150 · 190	182 · 200 · 250	222 · 250 · 265

FE 1-Stage / Kademe

Model No.		Unit/Birim	Ratio Çevrim	50	70	90	120	145	180	220
Nominal output torque / Nominal Çıkış Torku	T_{2N}	Nm	3	17	50	125	268	482	940	1,420
			4	15	45	111	238	426	860	1,300
			5	14	42	104	223	401	835	1,270
			7	13	39	98	208	373	790	1,180
			10	12	37	92	198	356	760	1,140
Max. Acceleration Torque / Max. İvmelenme Torku	T_{2B}	Nm	3~10	1.8 Times of Rated Output Torque / 1,8 x Nominal Çıkış Torku						
Max. Output Torque / Max. Çıkış Torku	T_{2NOT}	Nm	3~10	3 Times of Rated Output Torque / 3 x Nominal Çıkış Torku						
Rated Input Speed / Nominal Giriş Devri	n_{1N}	rpm	3~10	3,000	3,000	3,000	3,000	3,000	2,000	2,000
Max. Input Speed / Max. Giriş Devri	n_{1B}	rpm	3~10	5,000	5,000	5,000	5,000	5,000	3,000	3,000
Backlash / Boşluk Oranı		arcmin	3~10	≤ 8	≤ 8	≤ 8	≤ 8	≤ 8	≤ 8	≤ 8
Torsional Rigidity / Burulma Direnci		Nm/arcmin	3~10	2.3	5	15	45	69	140	220
Max. Radial Force / Max. Radyal Yük	F_{2rB}	N	3~10	750	1,180	3,000	6,500	9,100	11,150	35,000
Max. Axial Force / Max. Aksiyel Yük	F_{2aB}	N	3~10	325	590	1,500	3,250	4,550	5,575	17,500
Service Life / Hizmet Ömrü	L_H	hr	3~10	S5 Döngüsel Çalışma: >30,000 (S1 Sürekli Çalışma: >15,000 saat) S5 Cycle Operation: >30,000 (S1 Continuous Operation: >15,000 hrs)						
Efficiency / Verim	η	%	3~10	≥ 97%						
Operating Temperature / Çalışma Sıcaklığı		°C	3~10	-25° C ~ +90° C						
Lubrication / Yağlama			3~10	Synthetic Grease / Sentetik Gres						
Protection Class / Koruma Sınıfı			3~10	IP65						
Mounting Position / Montaj Pozisyonu			3~10	Any / Her Yönde						
Noise Level / Ses Seviyesi		dB	3~10	≤ 62	≤ 62	≤ 65	≤ 68	≤ 70	≤ 70	≤ 70
Weight / Ağırlık ±3%		Kg	3~10	0.63	1.57	3.22	8	16	33	54

Mass Moments of Inertia / Atalet Ağırlık Momenti (kg.cm²)

Ratio / Çevrim	50	70	90	120	145	180	220
3	0.04	0.14	0.61	3.25	8.75	24.63	50.67
4	0.04	0.13	0.48	2.74	7.16	20.12	46.21
5	0.04	0.11	0.47	2.74	6.84	19.80	45.28
7	0.04	0.11	0.44	2.58	6.78	19.21	43.32
10	0.04	0.11	0.44	2.57	6.68	19.13	42.98

MODEL : FE

RATIO / ÇEVİRİM : 15, 20, 25, 30, 35, 40, 50, 70, 100 (2-Stage / Kademe)

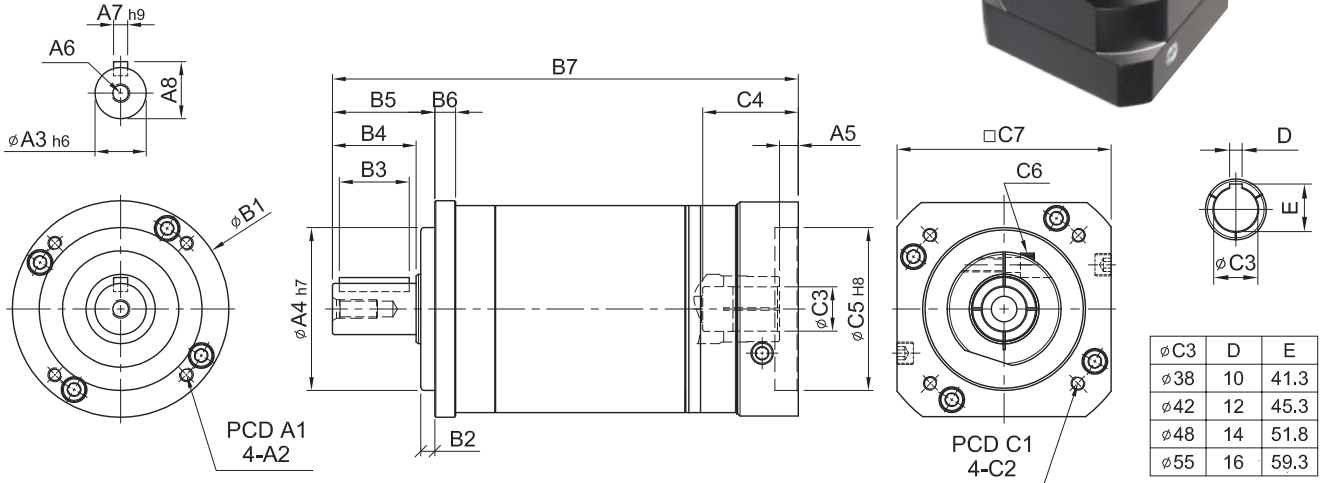

unit / birim : mm

Model Code	50	70	90	120	145	180	220	
A	A1	42	60	80	105	130	184	218
	A2	M4 x P0.7	M5 x P0.8	M6 x P1.0	M8 x P1.25	M10 x P1.5	M12 x P1.75	M16 x P2.0
	A3	13	16	22	32	40	55	75
	A4	35	50	70	90	110	160	180
	A5	5	6	9 · 23.5	10 · 20	10	13 · 15	13.5 · 15.5
	A6	M4 x P0.7	M5 x P0.8	M8 x P1.25	M10 x P1.5	M12 x P1.75	M14 x P2.0	M16 x P2.0
	A7	5	5	6	10	12	16	20
	A8	15	18	24.5	35	43	59	79.5
B	B1	Ø50	Ø70	Ø93	Ø122	Ø148	Ø205	Ø242
	B2	4	5	6	8	10	20	20
	B3	15	20	30	40	65	70	90
	B4	20	28	36	50	74	82	104
	B5	25	34	44	60	87	106	129
	B6	6	8	9	12	15	21.5	30
	B7	126.7	166.5	210.2 · 224.7	281.5 · 291.5	354.7	394.5 · 396.5	463.5 · 465.5
C	C1	46 · 60 · 63	70 · 75 · 90	90 · 100 · 115 · 145	115 · 145 · 165	145 · 165 · 200	200 · 215 · 265	200 · 265 · 300
	C2	M3 M4 M5	M4 M5 M6	M5 M6 M8	M6 M8 M10	M8 M10 M12	M10 M12	M12 M16
	C3	8 · 9 · 11	14 · 19	19 · 22 · 24	24 · 28 · 32	35 · 38	38 · 42 · 48	42 · 48 · 55
	C4	26	33.5	51 · 65.5	63 · 73	81.5	115 · 117	118 · 120
	C5	30 · 40 · 50	40 · 50 · 60	70 · 80 · 95 · 110	95 · 110 · 130	110 · 130 · 180	114.3 · 180 · 230	114.3 · 230 · 250
	C6	M4 x P0.7	M5 x P0.8	M6 x P1.0	M8 x P1.25	M10 x P1.5	M10 x P1.5	M10 x P1.5
	C7	46 · 55	64 · 70 · 80	92 · 110 · 130	122 · 130 · 150	146 · 150 · 190	182 · 200 · 250	222 · 250 · 265

FE 2-Stage / Kademe

Model No.		Unit/Birim	Ratio Çevrim	50	70	90	120	145	180	220
Nominal output torque / Nominal Çıkış Torku	T_{2N}	Nm	15	17	50	125	268	482	940	1,420
			20	15	45	111	238	426	860	1,300
			25	14	42	104	223	401	835	1,270
			30	17	50	125	268	482	940	1,420
			35	13	39	98	208	373	790	1,180
			40	15	45	111	238	427	860	1,300
			50	14	42	104	223	402	835	1,270
			70	13	40	98	208	373	790	1,180
			100	12	37	92	198	357	760	1,100
Max. Acceleration Torque / Max. İvmelenme Torku	T_{2B}	Nm	15~100	1.8 Times of Rated Output Torque / 1,8 x Nominal Çıkış Torku						
Max. Output Torque / Max. Çıkış Torku	T_{2NOT}	Nm	15~100	3 Times of Rated Output Torque / 3 x Nominal Çıkış Torku						
Rated Input Speed / Nominal Giriş Devri	n_{IN}	rpm	15~100	3,000	3,000	3,000	3,000	3,000	2,000	2,000
Max. Input Speed / Max. Giriş Devri	n_{IB}	rpm	15~100	5,000	5,000	5,000	5,000	5,000	3,000	3,000
Backlash / Boşluk Oranı		arcmin	15~100	≤ 12	≤ 12	≤ 12	≤ 12	≤ 12	≤ 12	≤ 12
Torsional Rigidity / Burulma Direnci		Nm/arcmin	15~100	2.3	5	15	45	69	140	220
Max. Radial Force / Max. Radyal Yük	F_{2rB}	N	15~100	750	1,180	3,000	6,500	9,100	11,150	35,000
Max. Axial Force / Max. Aksiyel Yük	F_{2aB}	N	15~100	325	590	1,500	3,250	4,550	5,575	17,500
Service Life / Hizmet Ömrü	L_{H1}	hr	15~100	S5 Döngüsel Çalışma: >30,000 (S1 Sürekli Çalışma: >15,000 saat) S5 Cycle Operation: >30,000 (S1 Continuous Operation: >15,000 hrs)						
Efficiency / Verim	η	%	15~100	≥ 94%						
Operating Temperature / Çalışma Sıcaklığı		°C	15~100	-25° C ~ +90° C						
Lubrication / Yağlama			15~100	Synthetic Grease / Sentetik Gres						
Protection Class / Koruma Sınıfı			15~100	IP65						
Mounting Position / Montaj Pozisyonu			15~100	Any / Her Yönde						
Noise Level / Ses Seviyesi		dB	15~100	≤ 65	≤ 65	≤ 68	≤ 70	≤ 72	≤ 72	≤ 72
Weight / Ağırlık ±3%		Kg	15~100	0.9	2.24	4.59	11.22	22.5	46.4	75

Mass Moments of Inertia / Atalet Ağırlık Momenti (kg.cm²)

Ratio / Çevrim	50	70	90	120	142	180	220
15	0.04	0.14	0.61	3.25	8.75	24.63	50.67
20	0.04	0.13	0.48	2.74	7.16	20.12	46.21
25	0.04	0.11	0.47	2.74	6.84	19.80	45.28
30	0.04	0.14	0.61	3.25	8.75	24.63	50.67
35	0.04	0.11	0.44	2.58	6.78	19.21	43.32
40	0.04	0.11	0.48	2.74	7.16	20.12	46.21
50	0.04	0.11	0.47	2.74	6.84	19.80	45.28
70	0.04	0.11	0.44	2.58	6.78	19.21	43.32
100	0.04	0.11	0.44	2.57	6.68	19.13	42.98